

Surge Protect Phone, Cable & Data Networks

NOTE: AC breaker panel protection is recommended when using data protection. Data protection diverts or dumps excess energy from data lines into the power grounding system. By strategically protecting branch breaker panels with the TPX, surge events will once again be equalized and safely contained at the breaker panel. This is what protects the ground and the power going to each power outlet.

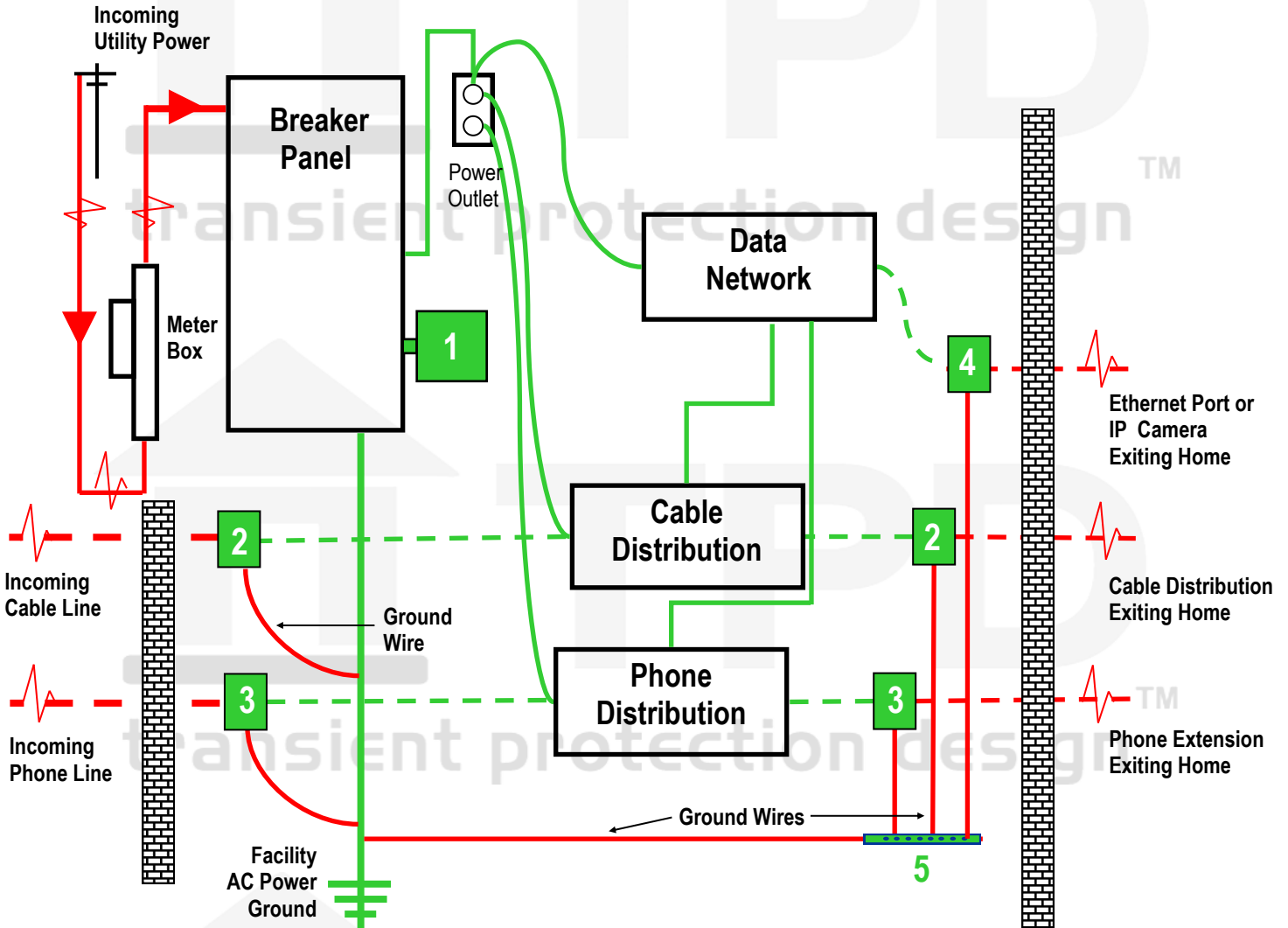

Transient Protection Design

- #1 TPX-1S240-F
- #2 TPD-CABLE
- #3 TPD-PHONE-RJ
- #4 TPD-CAT6 or TPD-CAT6-POE
- #5 TPD-GRD



Model #
TPD-CABLE



Model #
TPD-CAT6



Model #
TPD-GRD-7

Need additional assistance?
Call Technical Support
1-888-281-7856
info@TPDSurge.com
www.TransientProtectionDesign.com

* Depending on size, voltage and exposure level designers should refer to their product lists for a complete list of product options. If you do not have this list please email tim@tpdsurge.com for more information. Drawings are not to scale and should only be used as a visual representation. Installation instructions should be followed for optimal performance and adequate grounding.

© 2017 Transient Protection Design. All Rights Reserved. This drawing is the property of Transient Protection Design. The graphics, information and specific ideas in this document are the exclusive property of Transient Protection Design, and must not be made public, copied, or sold. Others seeking permission to reproduce this document, in whole or in part must obtain permission from Transient Protection Design in writing.